

Volume

1

CEMENT TEST EQUIPMENT, INC.

TULSA, OKLAHOMA, USA

Model 2000-5 UCA &

Model 2000-5-2 Dual

UCA

Instruction

Manual

CEMENT TEST EQUIPMENT, INC.

Model 2000-5 UCA & 2000-5-2 Dual UCA User's Manual

© Cement Test Equipment, Inc.
5704 E. Admiral Blvd.
Tulsa, OK 74115
Phone 918.835.4454 • Fax 918.835.4475
Rev. B



Table of Contents

INTRODUCTION	1	Transit Time Calibration	18
What is a UCA used for?	1	Changing the Disc Logging Interval	19
Description of Instrument.....	1	A TOUR OF THE FRONT PANEL	
Instrument Specifications	2	CONTROLS	20
Installation	3	The Hydraulic Pressure Controls.....	20
Connecting an Uninterruptible Power Supply (UPS) 5		The Pneumatic Controls.....	21
USING THE TOUCH SCREEN		The Cooling Water Controls.....	22
SOFTWARE	6	The Electrical and Electronic Controls and Displays	22
What is a touch screen and how does it work?	6	OPERATION	24
Using the Touch Screen.....	6	Preparing the Test Cell	24
What can you do with the touch screen software?	6	Setting Up a Temperature Ramp	25
Navigating the software	7	Setting Up Automatic Pressure Control	26
The Main Menu	7	Stopping a Test.....	27
Test Setup Menu.....	9	Cleaning the Test Cell	28
Instrument Setup Menu	11	MAINTENANCE AND	
Temperature Control	13	TROUBLESHOOTING	29
Running a Test.....	14	Maintenance	29
Stopping a Test	16	Troubleshooting	30
Use of the USB Memory Module.....	16	Parts List and Cross Reference	33
Networking the Instrument.	17		

Introduction

This chapter contains general information about the UCA and its uses as well as detailed specifications for the instrument and installation instructions.

What is a UCA used for?

ICON KEY	
	Important information
	Potential Danger or Safety Hazard
	Operational Warning

Cements are a critical element in the drilling, completion, workover, and abandonment of wells. For each application, a cement slurry is designed with specific properties and is given additives that provide predictable slurry density, volume, viscosity, compressive strength, fluid loss, gas migration, and thickening time. The Ultrasonic Cement Analyzer (UCA) is used to provide a history of the strength development of a cement slurry as it cures under elevated temperature and pressure.

Description of Instrument

The Ultrasonic Cement Analyzer transmits an ultrasonic pulse through a cement slurry and measures the travel time of the pulse through the slurry. The travel time of the pulse through the slurry gives an indication of the compressive strength of the slurry. The compressive strength, along with temperature and pressure, are monitored as a function of time for the purpose of providing a strength history of a setting cement slurry.

The major features of the CTE UCA are listed below:

- Easy to install and use.
- Direct replacement for Halliburton or Chandler UCA systems.

Our temperature controller and data acquisition system are so easy to operate you won't even need a manual. We've thrown one in anyway, just in case.

INTRODUCTION

- Completely self contained. No need for pressure controllers, control boxes, or PC's.
- All software is Windows® based.
- Data may be plotted on a standard ink jet printer, stored on a USB flash memory stick, or archived to an external PC via an Ethernet connection.
- Tests are stored as ASCII files and may be retrieved and viewed by most word processors, text editors, spreadsheets, and database programs.
- Has built in, easy to use, touch screen control panel for control of data acquisition and temperature control. No more clunky temperature controllers to program. Temperature profile is displayed graphically before test starts to reduce mistakes.
- Available with integral pump and relief valve for soak pressure control. Does not require separate pressure controller.
- May be used with Halliburton Pressure Controller as an option.
- Unit may be operated with an optional uninterruptible power supply (UPS) that will keep all functions (except heater) of the UCA operating for up to one hour during power outages.



A cross-reference list of Chandler and Halliburton part numbers and equivalent CTE part numbers is provided in *Chapter 5, Maintenance and Servicing*.

Instrument Specifications

The specifications below apply to the CTE, Inc. Model 2000-5 UCA and 2000-5-2 Dual UCA.

ELECTRICAL

Input Voltage:	230 VAC ($\pm 15\%$)
Input Power:	2500W
Input Current:	11 A (50 A Dual)
Input Frequency:	50-60 Hz

INTRODUCTION

MECHANICAL

	2000-5;	2000-5-2
Height:	12.6 in. (31.9 cm)	42 in. (107 cm)
Width:	20.8 in. (52.8 cm)	32 in. (81.3 cm)
Depth:	15.3 in. (38.9 cm)	21 in. (53.3 cm)
Weight:	110 lb. (50 kg)	300 lb. (136 kg)

ENVIRONMENTAL

Operating Temperature:	(32 to 120°F) 0-50°C
Operating Humidity:	0-95% non-condensing

HEATER

Heater Power:	2,000 W
Heater Type:	Cast heater with cooling coils
Heater Control:	Solid state relay

UTILITIES - WATER AND AIR

Compressed Air:	100 psig (6.8 bar)
Cooling Water Pressure:	100 psig (6.8 bar) maximum
Utility Inlets:	¼ inch female NPT

Installation

Upon uncrating the instrument, verify that the instrument and any spare parts on the packing have been received and are undamaged. Notify CTE if anything is missing or damaged.

It is a good idea to leave room behind the instrument so that qualified personnel may have service access. If this is not possible, try to make the unit easy to disconnect and move for service.

Once the instrument has been moved to its desired location, air, water, and electrical connections can be made. The air inlet, water inlet, and water drain connections are each ¼ inch female NPT connections and are located on the lower right rear of the instrument. A number of ¼ inch male NPT to 8mm tube fittings are included for international locations.

Connect the coolant and pressurizing water to the connectors labeled **COOLING WATER** and **WATER INLET**, respectively, on the rear panel of the instrument. Each fitting has a ¼ inch female N.P.T. connection. The water must be clean and free of debris that could cause failure of the pump or relief valve. A water filter (C-0739) is included and must be installed in the water inlet line to promote trouble free pump and relief valve operation. The part number for the water filter element is C-0739-1.

INTRODUCTION

Connect drain lines to the connectors labeled **WATER DRAIN** and **COOLING DRAIN** on the rear panel of the instrument. The fittings have ¼ inch female N.P.T. connections. The drain system must be capable of handling hot water up to 212 °F (100°C) or brief surges of up to 400°F (204°C) steam for short periods of time during initial cooling of the instrument. If two or more UCA's are connected to a common drain line, it is recommended that the drain be 3/8 inch (10mm) inside diameter, minimum. It is also recommended that the drain system be all metal.

Connect the air supply to the connector labeled **AIR INLET** on the rear panel of the instrument. The fitting has a ¼ inch female N.P.T. connection. The air should be dry and relatively free from dirt and oil. The air should be supplied at a pressure of 20-100 psig (1.4-6.8 bar). Compressed nitrogen may also be used in place of the compressed air if necessary.



- If high pressure bottles of nitrogen or air are used to operate the instrument, make certain that the pressure supplied to the instrument does not exceed 100 psig (6.8 bar). Applying high pressure gas to the instrument can cause tube rupture and possible injury.

Electrical connections are made using the receptacle on the rear of the instrument. A power cord (part number C-0156) is supplied with the instrument. Please observe the following precautions when making the wiring connections.



- Wiring should be done by a qualified installer in accordance with local electrical codes.
- The instrument should be securely connected to a separate earth ground. The ground wire must be larger in diameter than the supply conductors
- An 8BC or larger fire extinguisher to fight electrical and oil fires should be placed within 50 feet of the consistometer.

Before plugging the monitor into the rear of the UCA, make certain power to the instrument is off.

Some components such as touch screen LCD monitors, may be removed from the instrument prior to shipment and shipped in a separate container to prevent damage. This device must be reinstalled before operating the instrument. The cable on the touch screen monitor must

INTRODUCTION

be plugged into the connector labeled MONITOR located on the rear of the UCA.

If a printer is included with the instrument, it may be connected to the rear of the UCA. Connect the 25 pin D-sub connector on the printer cable to the connector labeled **PRINTER/ ZIP™ DRIVE**. The printer must also be connected to a suitable power source. Refer to the printer documentation for power requirements. An Iomega ZIP™ Drive may also be connected to the instrument in addition to the printer. The ZIP™ Drive is similar to a large diskette drive and holds approximately 100MB of data. Test data may be downloaded to the ZIP™ drive and then transferred to a PC for archival storage. Refer to Chapter 2, *Using the Touch Screen Software*, for more information on printer and ZIP™ Drive operation.

Connecting an Uninterruptible Power Supply (UPS)



If a UPS is not used, the C-0275 cord must be installed between the two rear panel receptacles or the instrument will not operate.

There are two receptacles on the rear of the unit labeled **UPS** that may be used to connect an uninterruptible power supply (UPS). In the event of a power failure, the UPS will operate all functions of the UCA, except the heater, for up to one hour to prevent loss of test. To connect the UPS, select the power cord supplied with the UPS and connect one end to the **UPS** input and the other end to the UCA. The cord will fit only one receptacle. Locate the other power cord supplied with the instrument (part number C-0275) and connect one end to the output of the UPS and the other end to the other **UPS** receptacle on the rear of the UCA. Press the ON button on the UPS. A green light will appear on the UPS when it is operating properly. If the unit beeps and a red light comes on, a power failure has occurred and the unit is being powered by the UPS. Note that if the **POWER** switch is turned OFF and the UPS is not turned OFF, the instrument will not power down.

Before attempting to operate the instrument, it is recommended that the operators read the remainder of the manual and study the drawings that appear in the Drawings/Schematics section of this manual to become familiar with the UCA operation.

Using the Touch Screen Software

This chapter contains specific information on how to use the touch screen software plus instructions on how to network the UCA and connect and use the USB Memory Module.

What is a touch screen and how does it work?

Touch screens were created to provide operators with an easy to use interface. They allow the user to input and view data without a keyboard or mouse. The touch surface is able to detect contact and send position information back to the processor. Using the touch screen has the same result of using a mouse to point and click. One mouse click is accomplished by one touch of the screen. A double-click is achieved with two quick touches. With this standard method of input, no special software is required to utilize the screen.

Using the Touch Screen

Most any object may be used on the touch-screens. Experimentation will quickly show which objects will activate the screen and which will not. It is important to note the touch surface does NOT use pressure to detect input. A light touch is all that is needed. In addition sharp instruments (such as pencils, pens, screwdrivers, etc.) should not be used as they may damage the touch surface.

What can you do with the touch screen software?

The purpose of the touch screen is to provide the user with a single interface to the instrument. Temperature control, instrument setup, and current test data are accessed through the touch screen. This eliminates

the need to individually program separate temperature controllers or other off-site PC software to begin running a test. Additionally, the touch screen allows the user to access current information from the instrument during a test. Each instrument is complete and requires no additional software or hardware to function.

Navigating the software

The software is designed to be intuitive to the user. In addition to the options, the different screens include directions and helpful hints to allow the user to quickly setup and run the instrument. The first-timer will find an easy to follow path to set up a test. Most users will become highly proficient within a very short time.

The Main Menu

The main menu is the starting point for the instrument. From here, users may start new tests, setup test parameters, setup instrument parameters, or view an old test. Also located at the bottom is the current temperature reading for the thermocouple. Current pressure is also displayed. The operator may also select the algorithm and the units of measure from the pull down boxes on the Main Menu. The Exit button is used to stop the UCA software and go into the Windows® operating system.

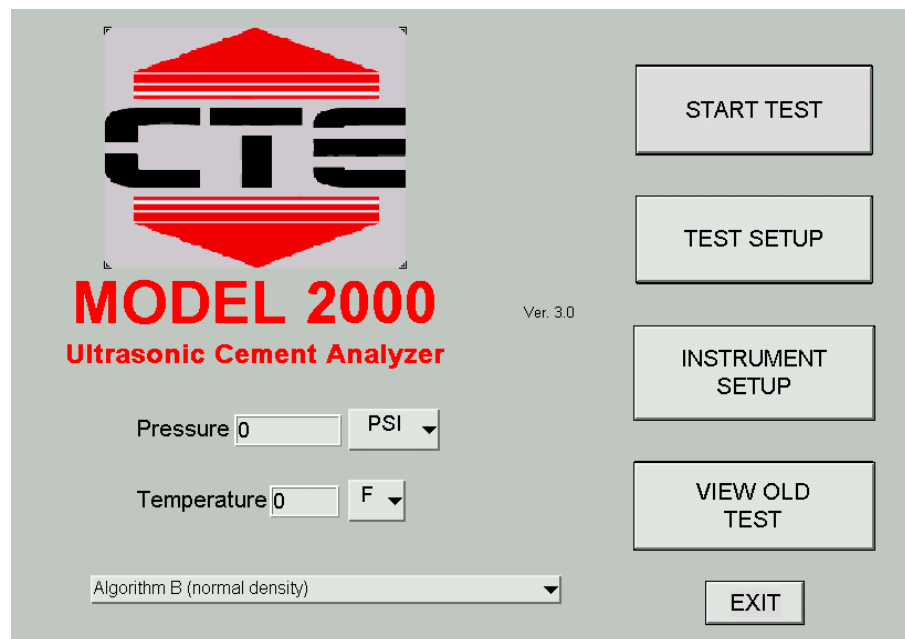

USING THE TOUCH SCREEN SOFTWARE

Please note the software version number underneath the CTE logo. This should consist of a number and perhaps a letter, for example, **2.1b**. This version number is important when calling CTE for support or questions.

As noted in the instructions on the screen, all the user needs do is touch a button to begin.

START TEST – Pressing this button begins a test. The instrument takes the current test parameters and begins a new test. If a temperature profile has been programmed, a screen will prompt the user to turn on the heater. Once a test has started you will be prompted for a file name and the main graph screen will be displayed.

TEST SETUP – This button takes the user to the Test Setup Screen. Here the user may enter test parameters for the instrument. Alarm Values, Calibration, and Temperature Control are all accessed through this screen.

INSTRUMENT SETUP – This button takes the user to the Instrument Setup Screen. From this screen the user may verify transducer signal or archive the data to a USB memory module or ZIP disk.

VIEW OLD TEST – This button allows the user to view any previously stored test. The software looks for the tests in the c:\data directory and you will be prompted to select a file. Use care when choosing a file name so you will be able to retrieve it if desired. Once the tests have been archived, the archived tests will not be viewable on the UCA itself, but may be viewed on any PC using the UCA Remote Viewer software.

Test Setup Menu

From this menu the user can setup the parameters for the next test.

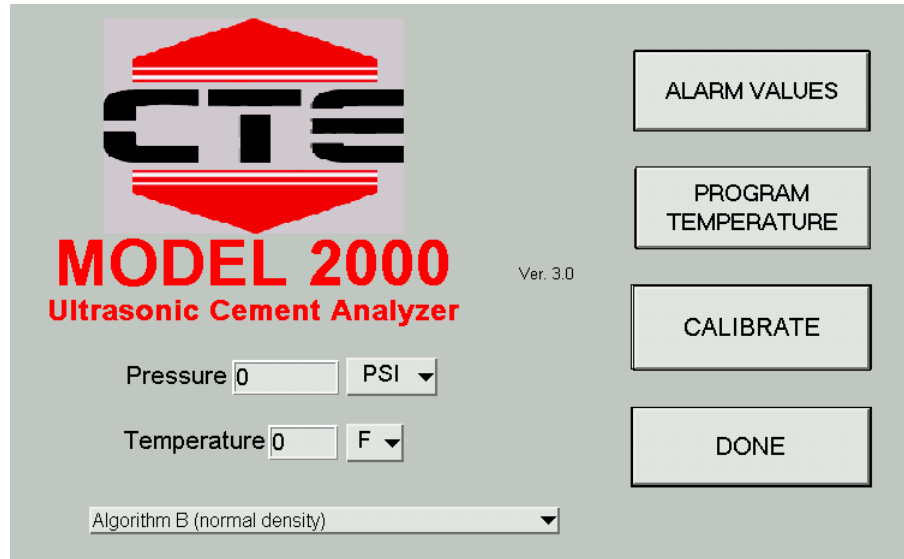

ALARM VALUES – The Alarm Values Button allows the user to enter up to three alarm values for compressive strength. The PC will notify the user when these values have been reached and at what time they were reached. Note that when the strength reaches the third alarm, the test automatically stops. To disable this feature, simply set the alarm value to a level that can never be reached, such as 100,000 psi.

Alarm Value 1
 psi

Alarm Value 2
 psi

Alarm Value 3
 psi

1	2	3
4	5	6
7	8	9
	0	BACK

Notice: Test will automatically terminate when Alarm Value 3 is reached.

PROGRAM TEMPERATURE – The Program Temperature button displays the setup screen to enter a temperature profile. This will be discussed further in a later section.

CALIBRATE – The Calibrate button gives the operator the option of calibrating either temperature, pressure, or transit time.

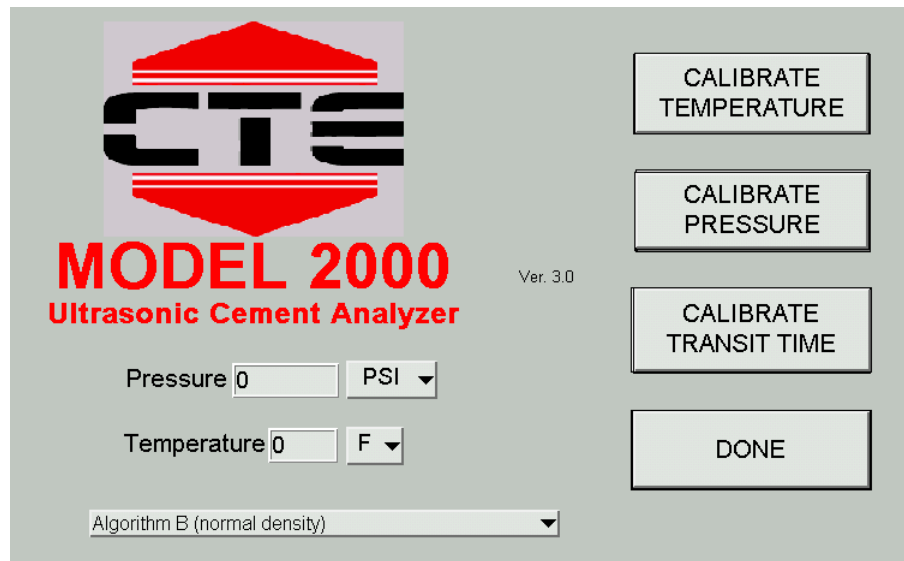

To calibrate the transit time, the cylinder must be COMPLETELY full of water with no air bubbles inside the cell. Calibration of transit time is discussed in more detail at the end of this chapter.

******NOTE: NEVER CALIBRATE TRANSIT TIME WITH A CEMENT SLURRY OR STEEL BAR FROM OTHER DEVICES**

Instrument Setup Menu

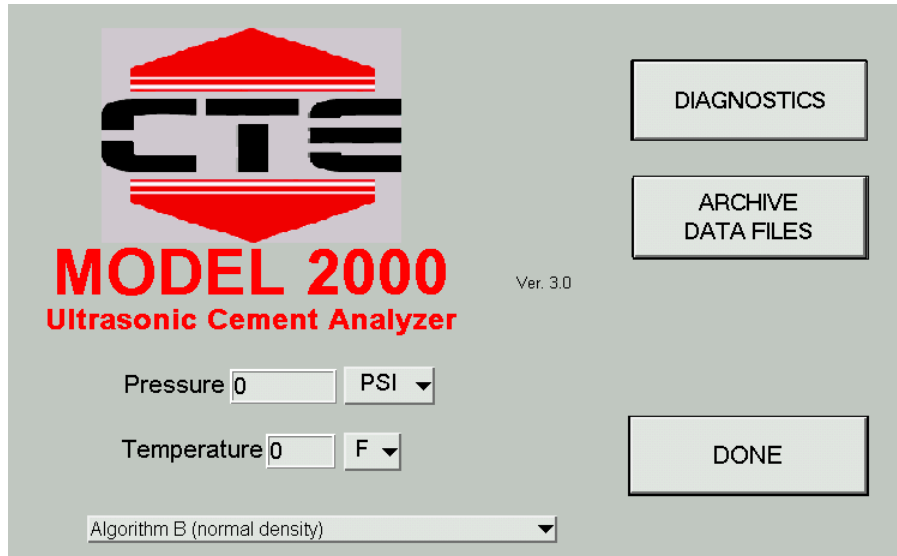

From this menu the user can run diagnostics on the ultrasonic transducer circuitry to determine if everything is functioning properly. This menu is also used move the data files from the UCA computer to another PC in order to free space in the UCA memory.

ARCHIVE DATA FILES – Select this command to move tests from the UCA to the USB memory module or external ZIP™ Drive. If the instrument reports a “Disk Full” message, it will be necessary to do this before additional tests may be run. After this step is completed, the stored tests on the UCA are moved then deleted. After this button is pressed a message box similar to the one below will appear indicating which files were copied from the UCA to the storage device.

Moving files.....

USING THE TOUCH SCREEN SOFTWARE

DIAGNOSTICS – The Diagnostics button displays a diagnostic screen where the user may pulse the transducer and display the waveform on the screen. This tool allows the user to quickly verify transducer operation. The peak of the transducer should be well above 200 with water in the vessel. If the pulse amplitude is less than 200 with water in the cell, the UCA will not function properly and an error message will be displayed.

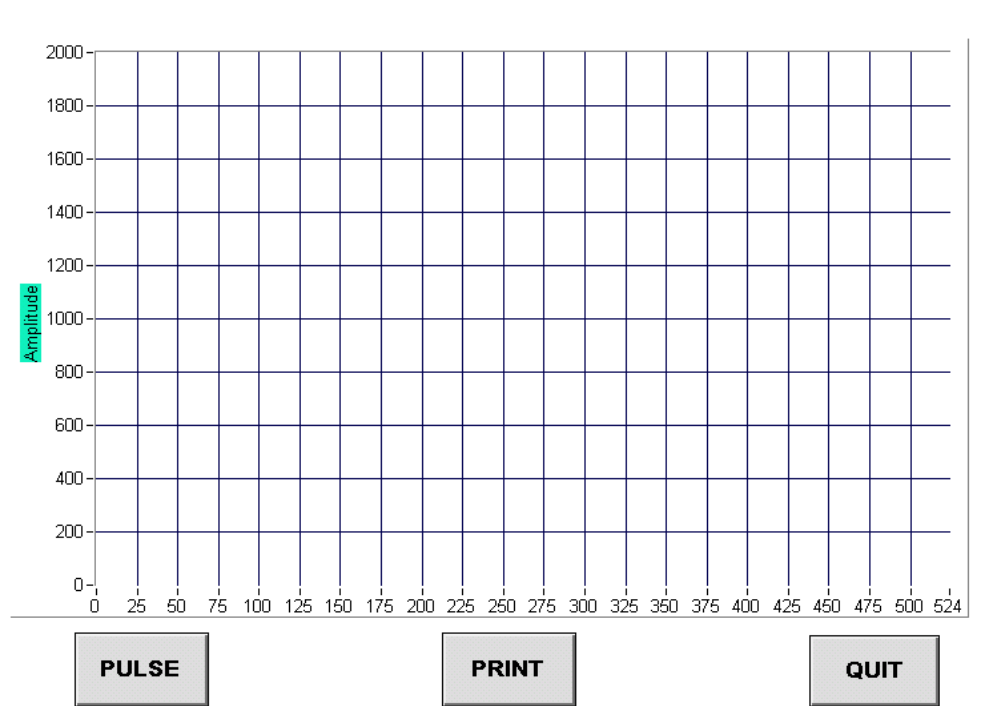

Temperature Control

No longer is entering a temperature ramp a confusing process. On the temperature setup screen is a standard numeric keypad. On the left side are three values that define a ramp. Once a ramp is entered the user may advance to the **Next Ramp** or press **Done** to finish.

Start Value	<input type="text"/> F	<table border="1"> <tr><td>1</td><td>2</td><td>3</td></tr> <tr><td>4</td><td>5</td><td>6</td></tr> <tr><td>7</td><td>8</td><td>9</td></tr> <tr><td>SOAK</td><td>0</td><td>BACK</td></tr> </table>	1	2	3	4	5	6	7	8	9	SOAK	0	BACK
1	2		3											
4	5		6											
7	8		9											
SOAK	0		BACK											
End Value	<input type="text"/> F													
Ramp Time	<input type="text"/> min													
	<input type="button" value="Next Ramp"/>													
	<input type="button" value="Done"/>													

When finished, a graph of the desired temperature ramp is displayed. The user may accept the current profile and continue or cancel to make further modifications.

Once the first ramp has been entered, press the **Next Ramp** button to proceed to the next ramp or **Done** to end the profile programming. If you end the programming at this point and start the test the temperature will reach set point and then fall because there was no second ramp or soak entered.

From this screen a second ramp may be entered or the user can enter a soak. To initiate a soak the user must use the **Soak** keypad button in the **Ramp Time** box. This will tell the computer to hold continuously at the programmed temperature. If you enter **Soak** as the time, the **Start Value** temperature and the **End Value** temperature must be the same. After entering all of your ramps and soak, you may press **Done** to complete the programming process. If you press **Done**, a graph will be

displayed showing exactly what you have entered for your temperature profile as shown below.

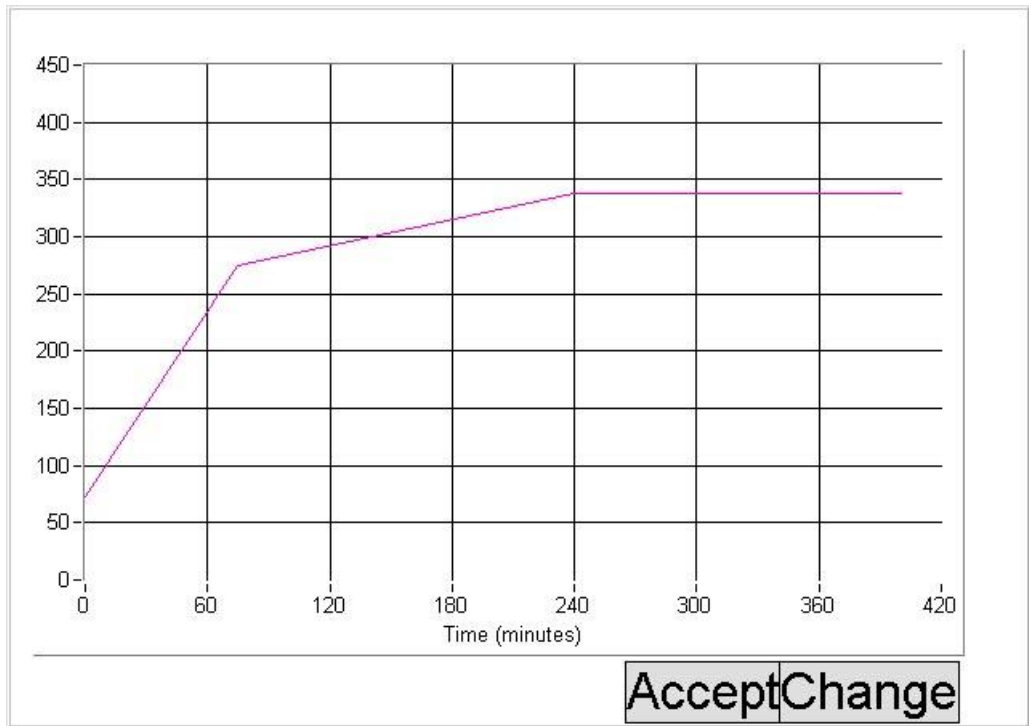

From this screen the user may press **Accept** if the graph is correct or **Change** to go back to the programming screens to correct any programming errors. If **Accept** is pressed the TEST SETUP screen will be displayed again. From here press DONE and the main menu will appear. Press START TEST to begin the test or any of the other buttons to change alarm values, slurry type, etc.

Running a Test

Once a test has begun, a real-time graph of current values will be displayed. The user may print the graph at any time by pressing the **PRINT PLOT** button located at the bottom of the screen. (Please note that a printer must be connected to the instrument before trying to print.) Pressing the **VIEW DATA** button displays the text version of the current values and parameters. From this screen the user may return to the graph or stop the test.

USING THE TOUCH SCREEN SOFTWARE

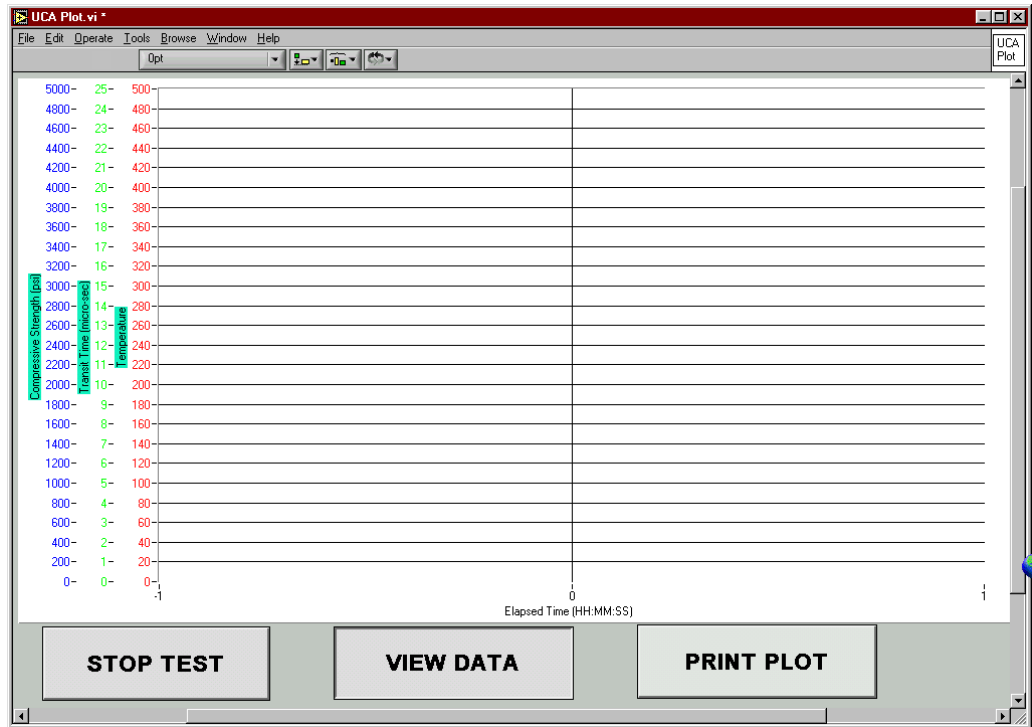

The screenshot shows the 'UCA Plot.vi' window with the 'Temperature Ramp' control panel. The panel includes the following controls:

- Temperature Ramp section with four rows: Ramp 1, Ramp 2, Ramp 3, and Ramp 4. Each row has a grid of input fields and a 'min' label.
- TIME: 0
- TEMPERATURE: 0
- SET POINT: 0
- TRANSIT TIME: 0.00
- Heater % Output: 0.0 (with a red indicator light)
- STRENGTH: 0
- PRESSURE: 0
- MESSAGE: [Empty text field]

At the bottom are three buttons: 'STOP TEST', 'VIEW PLOT', and 'VIEW WAVEFORM'.

If there is some question as to whether the instrument is producing the desired ultrasonic waveform, the user may press the **VIEW WAVEFORM**

USING THE TOUCH SCREEN SOFTWARE

button. This will display a waveform similar to the one shown below. IT may take up to a minute for the waveform to be displayed since the software waits for the next pulse to occur. Note that the amplitude of the first waveform peak must be greater than 20 or an error will occur. If the waveform amplitude is less than 20, the instrument may have a faulty cable or ultrasonic transducer or the ultrasonic transducers may not have enough ultrasonic couplant (grease).

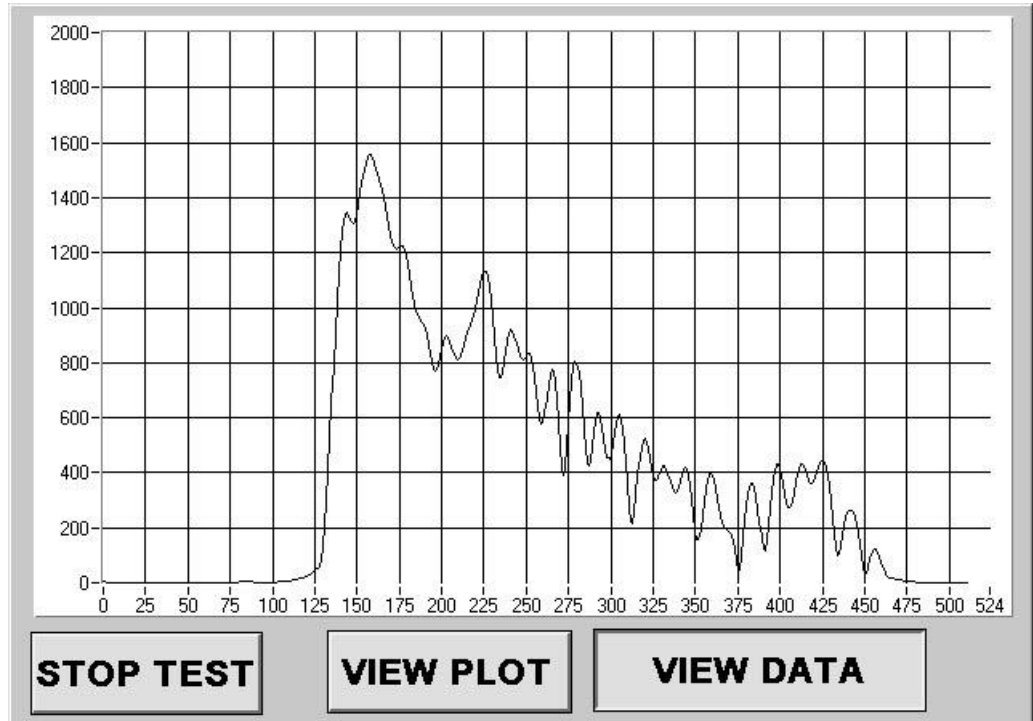

Stopping a Test

To stop the current test, the user must press the **STOP TEST** button on the CURRENT VALUES screen. Once the test has been stopped, no further data will be logged and no further temperature control will be provided. You may view the last test or any test stored on the UCA by pressing the **VIEW OLD TEST** button and selecting the appropriate file name.

Use of the USB Memory Module

The UCA operates under a version of the Windows[®] operating system. This allows the use of certain Universal Serial Bus (USB) peripherals, such

as USB flash memory modules. These USB memory modules may be used to archive or move UCA test files to another computer. The USB memory modules may be used without special drivers on any Windows XP or Windows 2000 based PC's. The memory module will simply appear as another disk drive when inserted into the USB port on the PC.



These USB memory modules require specific software drivers to be installed on the UCA before they can be used with the UCA. These drivers were installed at the factory and the supplied memory module should work with the UCA without incident. Note that the drivers required by the UCA work only with a specific brand of memory module. While any memory module will work with Windows 2000 or XP, only the specific module that came with the UCA, or one identical to it, will work with the UCA. To archive the stored tests on the UCA to the memory module, follow the steps below.

1. Make certain there is a folder titled *Data* on the memory module. This can be created most easily using a desktop PC.
2. Connect the memory module to the USB port on the UCA control box. No cables are required.
3. Press the **ARCHIVE DATA** button on the UCA touch screen. The files will be copied to the USB memory module and deleted from the UCA.
4. Once the files are copied to the USB memory module they may be moved to a desktop PC. Note that once the UCA data files are archived, they are no longer available for retrieval on the UCA. However, the UCA Remote Viewer may be used to view the archived tests from any location that has access to the data files.

Networking the Instrument.



The UCA may be connected to any Ethernet network (LAN). This makes it convenient to move UCA data files from one computer to another on the network. It is also possible to view a UCA test in progress or an old test from another computer networked to the UCA using the UCA Remote Viewer software. This will allow personnel to view a test in progress from home or on location, provided they have access to the network to which the UCA is connected.

Since the UCA operates under Windows[®] 98 or later, the instrument can be easily connected to a network. It may be necessary to assign an IP address to the instrument in some instances and this can be done in the

usual way through the system setup. The UCA should always be kept behind a secure network firewall to prevent unauthorized access via the internet or other portal. Allowing UCA access via the internet is not recommended.

Transit Time Calibration

Checking the transit time calibration is very easy. Follow the steps below.

1. Fill the cell with water, making certain there is no air trapped in the cell.
2. You may apply compressed air pressure of 60-180 psi to the cell if desired, but it is generally not necessary.
3. Connect all cables as at the start of a test.
4. Select **CALIBRATE TRANSIT TIME** from the touch screen menu. When the calibration screen appears, press the **CALIBRATE** button. If the waveform appears acceptable, press **DONE** to save the new calibration values. In general, the peak amplitude should be 600 or greater with water. If an acceptable waveform is not displayed, check the transducers and cables and recalibrate.

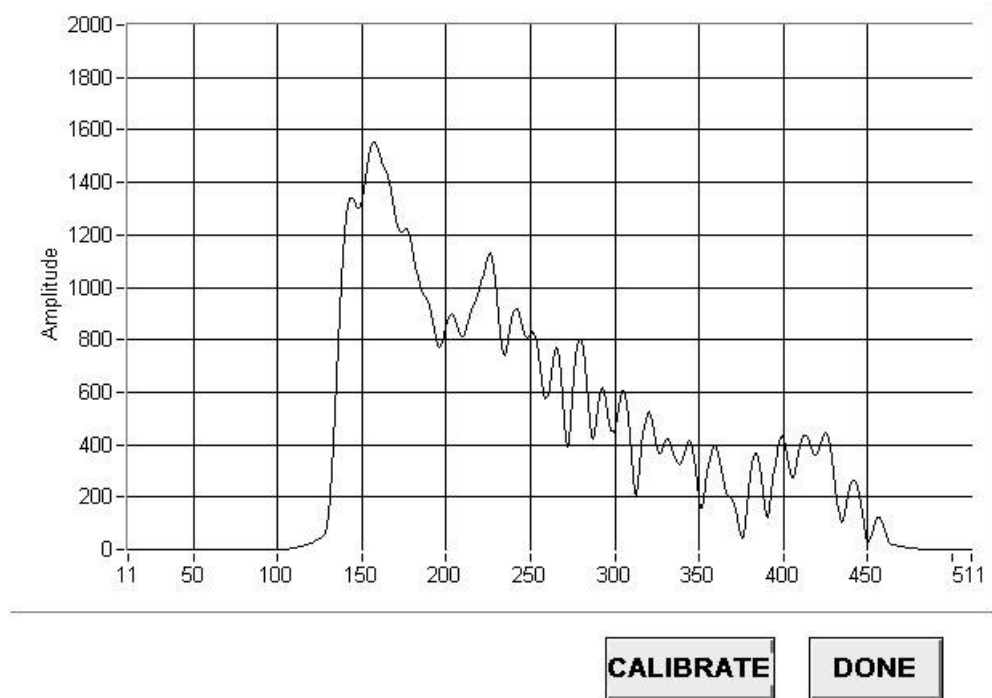

Transit time calibration is different from older UCA's. The steel calibration bar is no longer required. The unit is now calibrated with water. It is imperative that there be no air in the water during calibration or while a test is in progress.

Incorrect or improper calibration values are the most likely reason for the UCA to report incorrect strength values. The calibration should be checked whenever the transducers are removed or if the compressive strength values become suspect.

Changing the Disc Logging Interval

The interval at which data is written or logged to the disc drive may be changed if necessary. The default logging interval is one minute. On long term tests it may be necessary to increase the logging interval to prevent creation of unnecessarily large data files.

To change the logging interval, the user must manually edit a text file called m2000v3.dat. This file is found in the c:\data folder on the UCA disk drive. The contents of a typical file is shown below. The comments in red are descriptions and will not be found in the data file.

```
50          Alarm value 1. May be changed in UCA software.
500         Alarm value 2. May be changed in UCA software.
2500        Alarm value 3. May be changed in UCA software.
1           Logging interval in minutes. May be edited manually.
75.0        Temperature tuning parameters. Do not change.
150.0
0
45.0
100.0
0
35.0
50.0
0
```

This file may be edited using Notepad or any other text editor. Use caution when editing this file. Changing the formatting or any of the values other than the logging interval can cause improper operation of the UCA.

A Tour of the Front Panel Controls

Chapter 3 will discuss in detail each front panel control found on the UCA.

It may be convenient to refer to the piping drawings in Chapter 6 when studying this section.

The sections below will describe the function of each component found on the front panel. The controls can be divided into four categories: hydraulic controls that control the pressure inside the reservoir, pneumatic controls that control the air pressure to the pump, cooling water controls that control the flow of cooling water to the cooling coils, and the switches that control the electrical components of the instrument.

The Hydraulic Pressure Controls

This section consists of the following controls: the **PRESSURE RELEASE** valve, the **PRESSURE REGULATOR**, the **PRESSURE REGULATOR SHUTOFF** valve, and the **WATER SUPPLY** valve. Components that make up this section are used to control the flow of water used to pressurize the cylinder.

The **PRESSURE RELEASE** valve is used to release pressure from the pressurized cylinder. This valve must be closed during testing except when it is necessary to manually release pressure. This valve must also be closed when removing the pressure vessel with cooling water circulating or cooling water may back up and leak out the pressure port in the top of the instrument. The part number for the **PRESSURE RELEASE** valve is C-0656.

The **PRESSURE REGULATOR** may be used to set the upper limit on the system pressure up to 5,000 psig/340 bar. When the hydraulic force on the regulator exceeds the spring force of the regulator, the regulator valve will open and release pressure until the hydraulic and

spring forces balance again. The regulator will then close preventing any additional pressure release until the hydraulic force again exceeds the spring force. Turn the **PRESSURE REGULATOR** knob clockwise to increase pressure and counterclockwise to reduce pressure. The use of the pump and **PRESSURE REGULATOR** to control pressure automatically will be discussed in *Chapter 4*. The **PRESSURE REGULATOR** part number is C-0078-3.

The **WATER SUPPLY** valve is used to control the flow of water to the pump and test cell. This valve must be closed any time the test cell is not installed. This valve must be open to fill the pressure vessel with water or to operate the pump. Opening this valve when the test cell is not connected will cause a serious water leak. The part number for the water supply valve is C-0056.

The Pneumatic Controls

The pneumatic section consists of the **AIR SUPPLY** gauge, the **PUMP AIR PRESSURE ADJUST** regulator, and the **PUMP AIR PRESSURE** gauge. The components in this section are used to power the air driven hydraulic pump that applies pressure to the sample.

The **AIR SUPPLY** gauge indicates how much air pressure is being supplied to the instrument. The part number for the **AIR PRESSURE** gauge is C-0138. If there is no pressure indicated on this gauge, the pump will not operate. The pressure should be between 20 and 100 psig (1.4 and 6.8 bar) when the pump is not in use. It is normal for the inlet air pressure to drop when the pump is in operation. If the air pressure drops significantly and the pump seems unable to achieve the desired pressure, it may be because the compressed air system is not capable of delivering enough air to operate the pump.

The pressure gauge displays pressure in both English and SI units.

The **PUMP AIR PRESSURE ADJUST** regulator is used to control the air pressure to the air driven hydraulic pump. Higher hydraulic pressures require higher air pressures. To adjust the pressure of the air supplied to the pump, pull the knob on the regulator out to unlock it. Turn the regulator knob clockwise to increase the pressure and counterclockwise to decrease the pressure. When the adjustment is finished, push the knob in to lock it in place. The part number of this regulator is C-0021.

This regulator is used to control the pressure of the air supplied to the pump (part number C-0575-3). The hydraulic pressure output of the pump is directly proportional to the air pressure supplied to the pump. As the air pressure increases, the hydraulic pressures increases and vice versa. Air pressure to the pump may be decreased by turning the **PUMP AIR PRESSURE ADJUST** regulator knob counterclockwise or increased by turning the knob clockwise. If the regulator is set to a value and the pump switch is turned to the ON position, the pump will increase pressure until the pneumatic force of the air (air pressure multiplied by pneumatic piston area) equals the hydraulic force of the pressurizing water (water pressure multiplied by pump piston area). At this point the hydraulic and pneumatic pressures will be in equilibrium and the pump will cease to stroke. If the water pressure falls for some reason, a force imbalance will be created between the pneumatic and hydraulic sides of the pump and the pump will begin to stroke and increase the hydraulic pressure until it is balanced with the pneumatic pressure, then it will stop pumping. In this way, the pump may be used as a pressure control device (combined with the relief valve) to establish the lower pressure limit for a test. This will be discussed further in *Chapter 4*.

If the PUMP AIR PRESSURE drops off significantly when the pump is operating, an air line may be blocked or the compressor may be insufficient to deliver the volume of air required.

The **PUMP AIR PRESSURE** gauge shows the pressure of the air delivered to the pump. The pressure may be changed by adjusting the **PUMP AIR PRESSURE ADJUST** regulator as described above. The part number of this gauge is C-0138.

The Cooling Water Controls

The only cooling water control is the **COOLING WATER** valve. It is used to control the flow of cooling water to the heating/cooling jacket. This valve must be closed during a test, but should be opened following a test to cool the heater and test cell. The part number for this valve is C-0056.

The Electrical and Electronic Controls and Displays

The only front panel electrical controls are the **POWER**, **HEATER**, and **PUMP** switches. These controls are discussed in detail below.

A TOUR OF THE FRONT PANEL CONTROLS

If the unit is operated with an uninterruptible power supply (UPS), turning the POWER switch to the off position will not interrupt power. The UPS must also be turned off.

The switch labeled **POWER** controls electrical power to the entire instrument. Nothing else is operable if this switch is not on. The part number for the **POWER** switch is C-0075-1.

The **PUMP** switch opens or closes a solenoid valve that controls the flow of air to the pump. Turning this switch to the ON position causes the pump to increase pressure in the test cell. Turning the switch to the OFF position stops the pump from operating.

The **HEATER** switch is used to turn the flow of current to the heater ON or OFF. Switch must be in the ON position during testing and should be in the OFF position as a safety precaution at other times.

Operation

Chapter 4 will discuss in detail the steps required to run a compressive strength test. Examples will be provided when necessary.

Preparing the Test Cell

The steps that should be used to set up the test cell are listed below.

1. Apply a light coating of grease to the inside of the test cylinder, including the top and bottom plug surfaces that are in contact with the cement slurry. Coating the threads with grease or anti-seize lubricant is also recommended.
2. Screw the bottom plug into the bottom of the pressure cylinder. The top of the cylinder is stamped TOP on the wrench flats.
3. Add cement to the test cell until the proper fill level is obtained using the Slurry Level Gauge (P/N 4-0058-2). The slurry should touch the lower tab marked WET but not the upper tab marked DRY. Be careful not to get cement into the threads. If cement sets up in the threads it may make plug removal and installation difficult or impossible.
4. Gently pour a small amount of water into cylinder on top of the cement—just enough to reach the water fill line on the Slurry Level Gauge. Try not to mix the water and cement.
5. Screw the top plug in place. Do not tighten with a wrench. Hand tight or hand tight less 1/8 turn is optimal. A small amount of water should come out the pressure or thermocouple port when the top plug is in place.
6. Wipe the cylinder assembly clean and gently place in autoclave chamber. Make certain the electrical contacts in the bottom of the cabinet and plug are free from corrosion and debris. Rotate cylinder clockwise if necessary. To insure the banana connection on the bottom the cylinder assembly has good contact, make certain the test cell is pushed down firmly inside the heating

Do not overfill the test cell or cement will be forced into the pressure and/or thermocouple ports and plug them.

A small gap between the top and bottom plugs and the cylinder is advisable.

Overtightening does not cause better sealing; it only causes plug removal difficulty.

OPERATION

jacket. Do not turn the test cell assembly counterclockwise or the plugs may come unthreaded.

7. Connect the one end of the coaxial cable to the BNC connector on the top plug and the other end to the connector on the rear panel labeled **TRANSDUCER**.
8. Align pressure port in top plug with high pressure fitting on top of autoclave assembly. Rotate test cell in a clockwise direction only. The top or bottom plugs may come unscrewed if the test cell is rotated counterclockwise.
9. Attach the high pressure tube from the cabinet to the test cylinder. Place the U-shaped tube in place. Tighten fittings on both ends of U-tube finger tight only. When the U-shaped tube is in place, complete tightening using a 5/8 inch open end wrench.
10. Connect the thermocouple cable to the connector on the rear of the autoclave labeled **J THERMOCOUPLE**.
11. Install the thermocouple into the remaining high pressure port in the top plug of the test cell until the fitting is finger tight.
12. Slowly open the water supply valve until water begins to come out the thermocouple connection vent hole. Tighten the thermocouple with a 5/8 inch open end wrench. It is recommended a rag or paper towel be placed near the thermocouple vent hole to collect the spilled water and prevent it from running down inside the instrument or into the sensor cavity.

The instrument is now ready to begin a compressive strength test.

Setting Up a Temperature Ramp

To enter a temperature ramp press the square beside **START VALUE**. Enter the time you want it to take to reach the final temperature using the number pad on the right. The starting temperature is entered automatically by the processor, but may be changed by the user. Press the square beside **END VALUE** and enter final temperature. This completes the ramp. Now you probably want it to soak at the final temperature. Press **NEXT RAMP**. Enter how long you want it to soak or press the **SOAK** button to soak continuously until the test is stopped by the user or automatically stopped by auto shutdown. To keep it soaking at the same temperature the **START VALUE** and **END VALUE** temperature must be the same value. After you have entered the soak information press **DONE**. This will bring up a screen to show you how the graph should look during the test. If the graph is what you

entered and is correct, press the **ACCEPT** button. If not, press the **CHANGE** button.

Setting Up Automatic Pressure Control

This section describes the steps used to control pressure in the Model 2000-5 UCA. Use of the internal pump and pressure regulator will also be discussed.

Follow the steps below the to configure the pump and pressure regulator for automatic pressure control.

- 1.** Make certain the test cylinder is installed properly, the **PUMP** switch is in the OFF position, the **WATER SUPPLY** valve is turned to the ON position, the **COOLING WATER** valve is in the OFF position, and the instrument is supplied with compressed air.
- 2.** Turn the **PUMP AIR PRESSURE ADJUST** regulator clockwise until air pressure is sufficient to raise pressure to the desired pressure set point. The air pressure should not exceed 100 psig (690 kPa).
- 3.** Turn the blue **PRESSURE REGULATOR** knob clockwise until the regulator pressure is sufficient to prevent the regulator from opening at the required pressure set point.
- 4.** Turn the **PUMP** switch to the ON position and increase pressure until the pressure exceeds the desired set point. Turn the **PUMP** switch to the OFF position. Make certain the system is holding pressure before proceeding. The pump contains metal-to-metal inlet and outlet check valves that may not be bubble tight, so a small amount of pressure leakage is to be expected. This should not be a problem under normal operation.
- 5.** Turn the blue **PRESSURE REGULATOR** knob counterclockwise slowly until the test cylinder pressure begins to drop. Continue turning the regulator knob slowly until the pressure in the test cell is at the upper limit of the desired test pressure.
- 6.** Release pressure in the test cell using the **PRESSURE RELEASE** valve.
- 7.** Turn the **PUMP AIR PRESSURE ADJUST** regulator counterclockwise until the **PUMP AIR PRESSURE** is approximately zero.
- 8.** Turn the **PUMP** switch to the ON position.

OPERATION

9. Slowly turn the **PUMP AIR PRESSURE ADJUST** regulator knob clockwise until the pump actuates. Continue to slowly turn the regulator knob clockwise until the lower limit for the control pressure is reached.

As the test cylinder gets hot, pressure in the test cylinder will increase. When the pressure in the test cylinder exceeds the control pressure upper set point, the pressure regulator will open and pressure will be reduced. If the heating rate is reduced, as during the transition from a temperature ramp to a temperature soak, the pressure in the test cylinder may decrease. If the pressure falls below the control pressure lower limit, the pump will actuate and bring the pressure back within the established limits.

The pump and pressure regulator will have hysteresis or a “deadband” in their operation. For example, if the pressure regulator is set to open at 3000 psig, it may open at 3000 psig, but may not close until the pressure falls to some lower value, perhaps 2900 psig. This 100 psig differential between opening and closing is referred to as the deadband or hysteresis. As another example, the pump may be set to actuate if the pressure falls to 3000 psig, but the pressure may reach perhaps 3100 psig before the pump stops. This 100 psig differential between the initial pressure and the final pressure is also known as deadband or hysteresis. If the upper and lower set points are too close together, this deadband may overlap and cause system instability. The system will then go into a continuous oscillation where the pump increases pressure and the pressure regulator releases all the pressure the pump is able to build. The solution to this problem is to decrease the lower set point, raise the upper set point, or both.

Stopping a Test

When the test has been completed, follow the steps below to end the test.

1. Turn the **HEATER** switch to the OFF position.
2. Open the **COOLING WATER** valve to cool the test cell. Use the pump to maintain pressure on the test cell until the cell is cool. When the temperature is below 200°F (93°C) the **PUMP** switch may be turned to the OFF position and the **PRESSURE RELEASE** valve opened. Failure to maintain pressure at temperatures above 212°F (100°C) may cause water in the test cell to vaporize into steam.
3. Turn **WATER SUPPLY** valve to its OFF position (clockwise).

OPERATION

4. Turn **POWER** switch to its OFF position.
5. Close the **PRESSURE RELEASE** valve (clockwise). Failure to do so will result in water leakage if cooling water is circulating when the U-tube or thermocouple are loosened.
6. Remove the U-shaped high pressure tubing connecting the test cylinder to the bulkhead fitting on the top of the instrument.
7. Disconnect the transducer cable.
8. Disconnect the thermocouple cable.
9. Lift the test cell from the instrument.

The test cylinder is now ready to be cleaned. Cleanup should be done as soon after completion of a test as possible when the sample is easiest to remove.

Cleaning the Test Cell

When the test cylinder has been cooled and removed from the instrument, it should be cleaned according the following guidelines.

1. Place the test cylinder in a vice, topside up. The top of the cylinder is marked on the cylinder wrench flats. Use the wrench flats to clamp the plugs and cylinder and do not scratch or nick the cylinder or plugs.
2. Remove the cylinder from the vice and replace in the vice top side down.
3. Unscrew and remove the bottom plug from the test cylinder.
4. Turn the cylinder over and tap the cement sample out of the test cell with a hammer. The cylinder is tapered outward from top to bottom so the cement sample must always be removed through the bottom of the cylinder.
5. Clean the cement and grease from the top and bottom plugs and cylinder.
6. When all traces of cement have been removed, grease the inner surfaces of the test cell, including the seals and o-rings.
7. Replace the o-rings if they were damaged during the test.

The test cylinder is now ready to be used for the next test.

Maintenance and Troubleshooting

This chapter contains information about the necessary periodic maintenance of the instrument as well as common service and troubleshooting guidelines.

Maintenance

UCA's can be relatively reliable and trouble free—provided they are serviced and maintained properly. Instruments that are neglected and receive infrequent service or are subject to abuse are certain to cause trouble. The maintenance requirements for UCA are very simple and should consume little time.

The first maintenance item is to check and replace the 2 micron filter element inside the filter housing periodically. The filter housing is located on top of the instrument cabinet and is connected to the tubing leading to the test cylinder. The filter housing should be thoroughly cleaned at this time. The filter is designed to prevent cement particles from entering the **PRESSURE REGULATOR** and damaging it.

The second maintenance item is to thoroughly clean and lubricate the test cylinder after every test. Be sure to inspect the o-rings for damage and replace if damaged or severely distorted.

Problems related to corrosion of the lower transducer connection can be minimized by not allowing water to run down the side of the cylinder and into the bottom of the instrument.

Periodically inspect the electrical connector in the bottom of the instrument where the test cylinder rests. If this connector get dirty or corroded, the lower transducer may not make good electrical contact. Clean the connector if necessary.

Unlike other UCA's, it is not necessary to coat the ultrasonic transducers with couplant prior to every test. In fact, the transducers should not be removed unless they are believed to be faulty or unless they need additional couplant. The top transducer is sealed to prevent water from entering the transducer chamber during cylinder filling or cleanup.

Troubleshooting

The following section consists of a table listing possible remedies for the most common UCA problems.

<i>Symptom</i>	<i>Cause</i>	<i>Remedy</i>
System builds pressure but will not hold pressure	Leak	Check fittings for leaks and tighten fittings.
	PRESSURE RELEASE valve is not closed tightly	Close valve tightly.
	PRESSURE RELEASE valve is worn out.	Replace valve stem or entire valve.
POWER circuit breaker switch trips off	Short circuit is system wiring.	Disconnect power to instrument and check for short circuits with an ohm meter.
	Faulty POWER switch.	Replace switch.
Pump strokes but little or no pressure is obtained	PRESSURE RELEASE valve open, severe leak, blown rupture disc.	Locate problem and correct.
	Test cylinder has trapped air.	Open thermocouple connector slightly and release trapped air.
	WATER SUPPLY valve is not open or water is not being supplied to the instrument.	Open WATER SUPPLY valve and check flow of water to the instrument.
	PRESSURE REGULATOR is not	Turn PRESSURE REGULATOR knob clockwise. Overhaul/replace regulator.

MAINTENANCE AND TROUBLESHOOTING

<i>Symptom</i>	<i>Cause</i>	<i>Remedy</i>
	holding pressure. Faulty pump check valve.	Clean and/or overhaul pump check valves.
Instrument not receiving power	Instrument not plugged in. Blown fuse or thrown breaker on circuit supplying power.	Connect instrument to the correct power source. Check fuses and breakers on electrical supply circuit.
Heater will not get hot.	Blown fuse. HEATER switch not in the ON position. Faulty heater. Faulty solid state relay.	Check fuses on rear panel. Replace any that are blown. Turn HEATER switch to ON position. Replace. Replace.
Temperature display is erratic.	Faulty thermocouple.	Replace thermocouple.
Temperature displays an unusually high number (>1500°F)	Loose connection in thermocouple wiring. Open circuit in thermocouple.	Check for loose wiring and correct if necessary. Replace thermocouple.
Pump will not operate.	Insufficient air pressure to pump. Solenoid valve controlling flow of air to pump is not functioning.	Check thermocouple circuitry for open circuits or loose connections. Correct if necessary. Check air supply and make certain instrument is supplied with air between 30 and 100 psig. Check air lines for blockage. Adjust PUMP AIR PRESSURE ADJUST regulator to a higher pressure. If no solenoid click is heard when the PUMP switch is turned to the ON position, a faulty solenoid valve is likely
Waveform amplitude is too low	Not enough ultrasonic couplant on transducers. Pressure is below 1000 psi Dirt or debris on transducer faces.	Clean transducers and apply new couplant. Pea size amount is sufficient. Increase pressure above 1000 psi. Clean transducers and apply new

MAINTENANCE AND TROUBLESHOOTING

<i>Symptom</i>	<i>Cause</i>	<i>Remedy</i>
Transit time and compressive strength values are erratic.	<p>Not enough ultrasonic couplant on transducers. Dirt or debris on transducer faces. Bad coaxial cable. Loose coaxial connector inside control box. Pressure was below 1000 psi during test</p>	<p>couplant. Clean transducers and apply new couplant. Pea size amount is sufficient.</p> <p>Clean transducers and apply new couplant. Replace cable. Check connections and tighten if necessary. Check data file and make certain pressure remains above 1000 psi during a test</p>
Water comes out of pump muffler.	<p>Faulty high pressure seal. Faulty spool valve o-ring.</p>	<p>Replace the high pressure seal and remove all water from air side of pump. Pump may also be sent back for repair. Install spool valve repair kit.</p>

Parts List and Cross Reference

The following table contains a list of spare parts for the CTE Model 2000-5 UCA. A list of equivalent Halliburton and Chandler part numbers is also listed.

CTE Part Number	Chandler Part Number	Halliburton Part Number	Description
4-0120			Pressure Vessel Assembly
4-0123			Bottom Plug
4-0121			Pressure Vessel
4-0124			Top Plug
4-0026	80-0019	800.30842	Handle, Top Plug
C-0681			O-Ring, Viton
C-0138			Gauge, Pressure, 160 psi
C-0371	C08584		Ultrasonic Transducers (pair)
C-0575-3			Pump
C-0078-3			Pressure Regulator
C-0079	C08582		Bulkhead Fitting, 1/4 HPT-1/4 HPT
C-0656			Valve, Pressure Release
4-0032	80-0022	800.30813	Heating/Cooling Jacket, 2000 W
4-0058-2			Slurry Level Gauge
C-0395			Spring
4-0035	80-0026	800.30824	Heating Jacket Centering Ring
4-0023	80-0024	800.30823	Heating Jacket End Gasket
4-0037			Heating Jacket Bottom Gasket
4-0110			Cable, Ass'y

MAINTENANCE AND TROUBLESHOOTING

CTE Part Number	Chandler Part Number	Halliburton Part Number	Description
C-0080			SSR, 240 VAC, 25A, DC Control
C-0132	P-3330	70.80037	SSR, 240 VAC, 25A, AC Control
C-0395-1			Spring
C-0266	P-3359	70.73543	Inlet, Electrical, 20 A, 250 VAC
C-0516			T/C, Type J
C-0056	P-0308		Valve, Brass, 1/4T-1/4T, Needle
C-0024			Solenoid Valve
C-0075-1			Switch, ON/OFF Circuit Breaker, 20A
C-0264	C08572	80.31035	Thermostat, 420 Open/380 Close
C-0737			Filter Assembly, SST
C-0587			Rupture Disc
C-0096			Pressure Transducer
C-0737-1			Element, for C-0737 Filter
C-0739			Water Filter
C-0739-1			Water Filter Element
C-0172			Printer Cable
C-0324			Fan
C-0481			Power Supply
C-0156			Power Cord
4-0065			Cylinder Wrench
C-0145			Monitor, Touch Screen

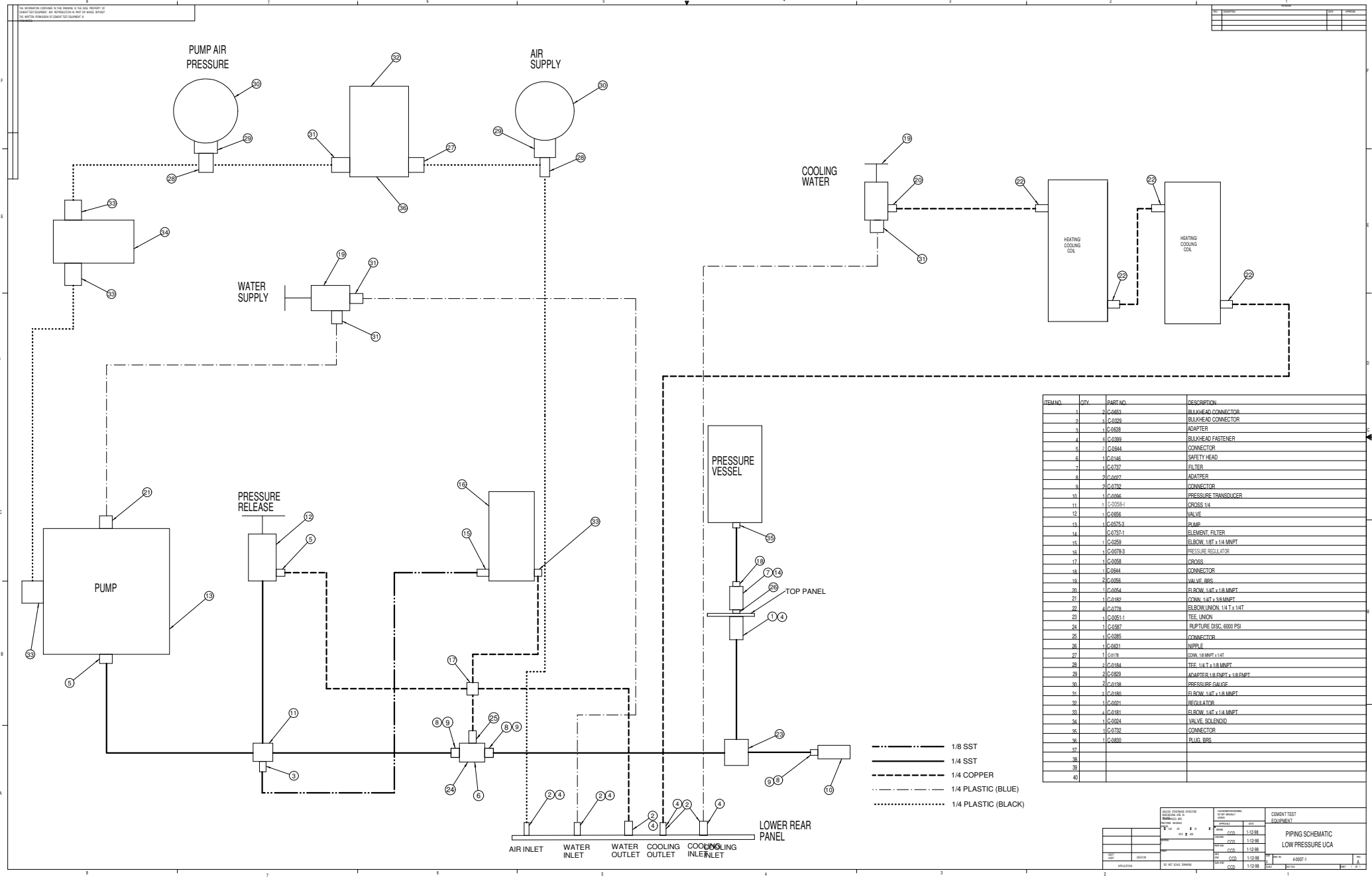

ITEM NO.	QTY	PART NO.	DESCRIPTION
1	2	C4883	BULKHEAD CONNECTOR
2	1	C41028	BULKHEAD CONNECTOR
3	1	C4888	ADAPTER
4	1	C4380	BULKHEAD FASTENER
5	2	C4844	CONNECTOR
6	1	C4146	SAFETY HEAD
7	1	C4737	ELBOW
8	2	C4707	ADAPTER
9	2	C4778	CONNECTOR
10	1	C4106	PRESSURE TRANSDUCER
11	1	C4055-1	CROSS 1/4
12	1	C4856	VALVE
13	1	C4875-3	PUMP
14	1	C4737-1	ELEMENT FILTER
15	1	C4259	ELBOW 1/8 T x 1/4 MNPT
16	1	C4078-3	PRESSURE REGULATOR
17	1	C4058	CROSS
18	1	C4844	CONNECTOR
19	2	C4056	VALVE SPS
20	1	C4054	ELBOW 1/4 T x 1/8 MNPT
21	1	C4182	DOWN 1/4 T x 3/8 MNPT
22	4	C4178	ELBOW UNION 1/4 T x 1/4 T
23	1	C4057-1	TEE UNION
24	1	C4587	RUPURE DISC 6000 PSI
25	1	C4885	CONNECTOR
26	1	C4801	NIPPLE
27	1	C4711	TEE 1/8 MNPT x 1/4 T
28	2	C4184	TEE 1/4 T x 1/8 MNPT
29	2	C4829	ADAPTER 1/8 ENPT x 1/8 ENPT
30	2	C4138	PRESSURE GAUGE
31	3	C4180	ELBOW 1/4 T x 1/8 MNPT
32	1	C4021	REGULATOR
33	1	C4181	ELBOW 1/4 T x 1/8 MNPT
34	1	C4084	VALVE SOLENOID
35	1	C4778	CONNECTOR
36	1	C4880	PLUG SPS
37			
38			
39			
40			

- 1/8 SST
- 1/4 SST
- - - 1/4 COPPER
- - - 1/4 PLASTIC (BLUE)
- · · 1/4 PLASTIC (BLACK)

DATE: 1/18/98 DRAWN BY: J. J. BROWN CHECKED BY: J. J. BROWN		APPROVED BY: J. J. BROWN DATE: 1/18/98		EQUIPMENT: PIPING SCHEMATIC LOW PRESSURE UCA	
REV	DESCRIPTION	DATE	BY	APP	REV
1	ISSUE	1/18/98	J. J. BROWN	J. J. BROWN	1
2	REVISED	1/18/98	J. J. BROWN	J. J. BROWN	2

THE INFORMATION CONTAINED IN THIS DRAWING IS THE SOLE PROPERTY OF CEMENT TEST EQUIPMENT, INC. ANY REPRODUCTION IN PART OR WHOLE WITHOUT THE WRITTEN PERMISSION OF CEMENT TEST EQUIPMENT, INC. IS PROHIBITED.

REV.	DESCRIPTION	REVISIONS	DATE	APPROVED

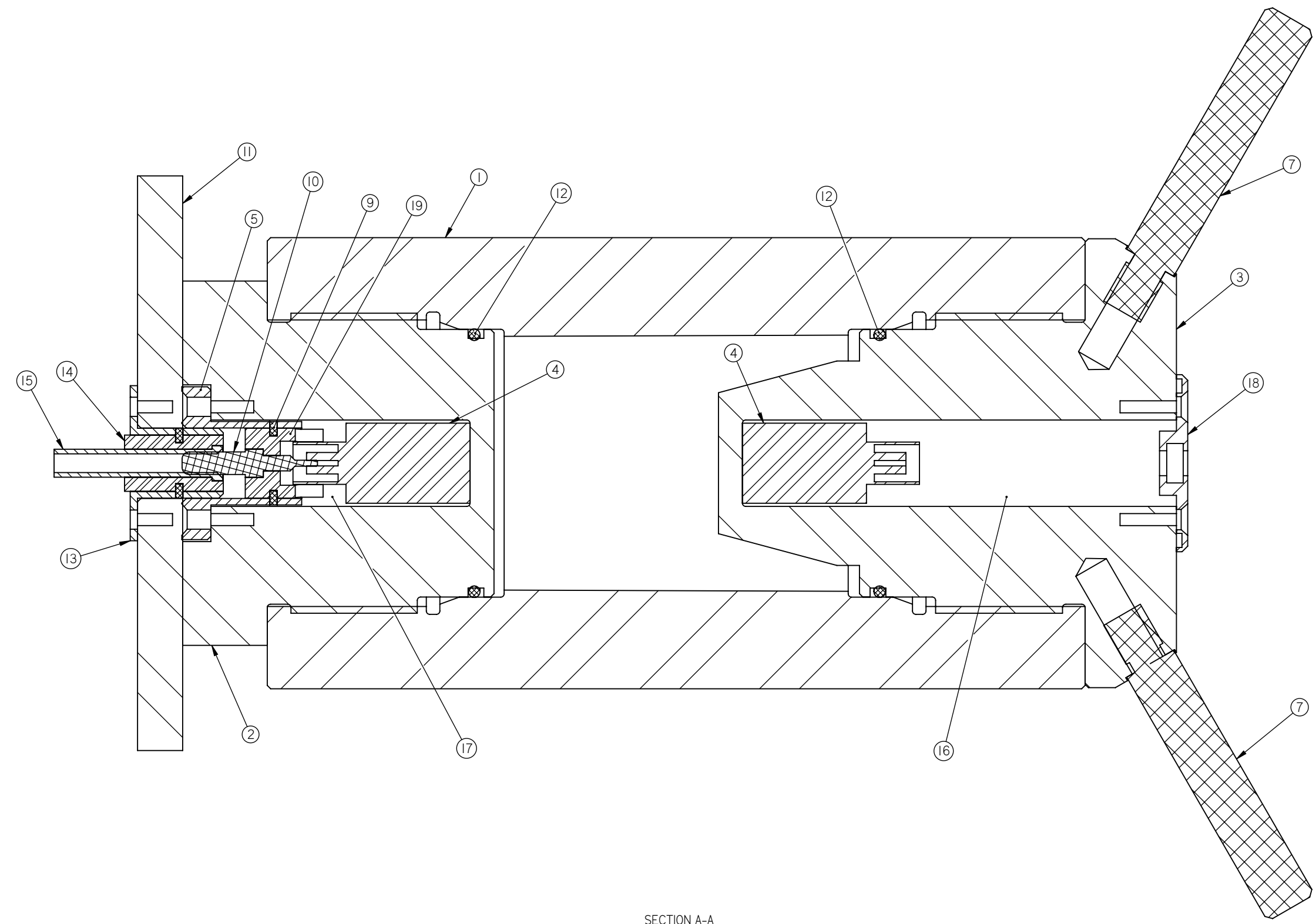

SECTION A-A

ITEM NO.	QTY.	PART NO.	DESCRIPTION
1	1	4-0121	CYLINDER
2	1	4-0123	BOTTOM PLUG
3	1	4-0124	TOP PLUG
4	2	C-0396	ULTRASONIC TRANSDUCER
5	1	4-0083	PLUG HOLDER
7	2	4-0026	HANDLE
9	4	C-0393	DOWEL PIN
10	1	4-0087	BANANA PLUG
11	1	4-0036	HEATER BASE
12	2	C-0681	O-RING
13	1	4-0085	JACK SUPPORT
14	1	4-0086	JACK INSULATOR
15	1	4-0089	BANANA JACK
16	1	C-0395-1	SPRING (NOT SHOWN)
17	1	C-0395	SPRING (NOT SHOWN)
18	1	4-0110	CABLE ASSEMBLY
19	1	4-0084	PLUG INSULATOR

UNLESS OTHERWISE SPECIFIED DIMENSIONS ARE IN INCHES
TOLERANCES ARE:
FRACTIONS DECIMALS ANGLES
+1/32 .XX +.01 +-1
.XXX +.005

CAD GENERATED DRAWING.
DO NOT MANUALLY UPDATE

CEMENT TEST EQUIPMENT, INC.

APPROVALS	DATE
DRAWN CCD	6-21-01
CHECKED CCD	6-21-01
RESP ENG CCD	6-21-01
MFG ENG CCD	6-21-01
QUAL ENG CCD	6-21-01

APPLICATION DO NOT SCALE DRAWING

SIZE DWG. NO. 4-0120 REV. A
SCALE 1:2 CAD FILE: SHEET 1 OF 1

CYLINDER ASSEMBLY
LOW PRESSURE UCA

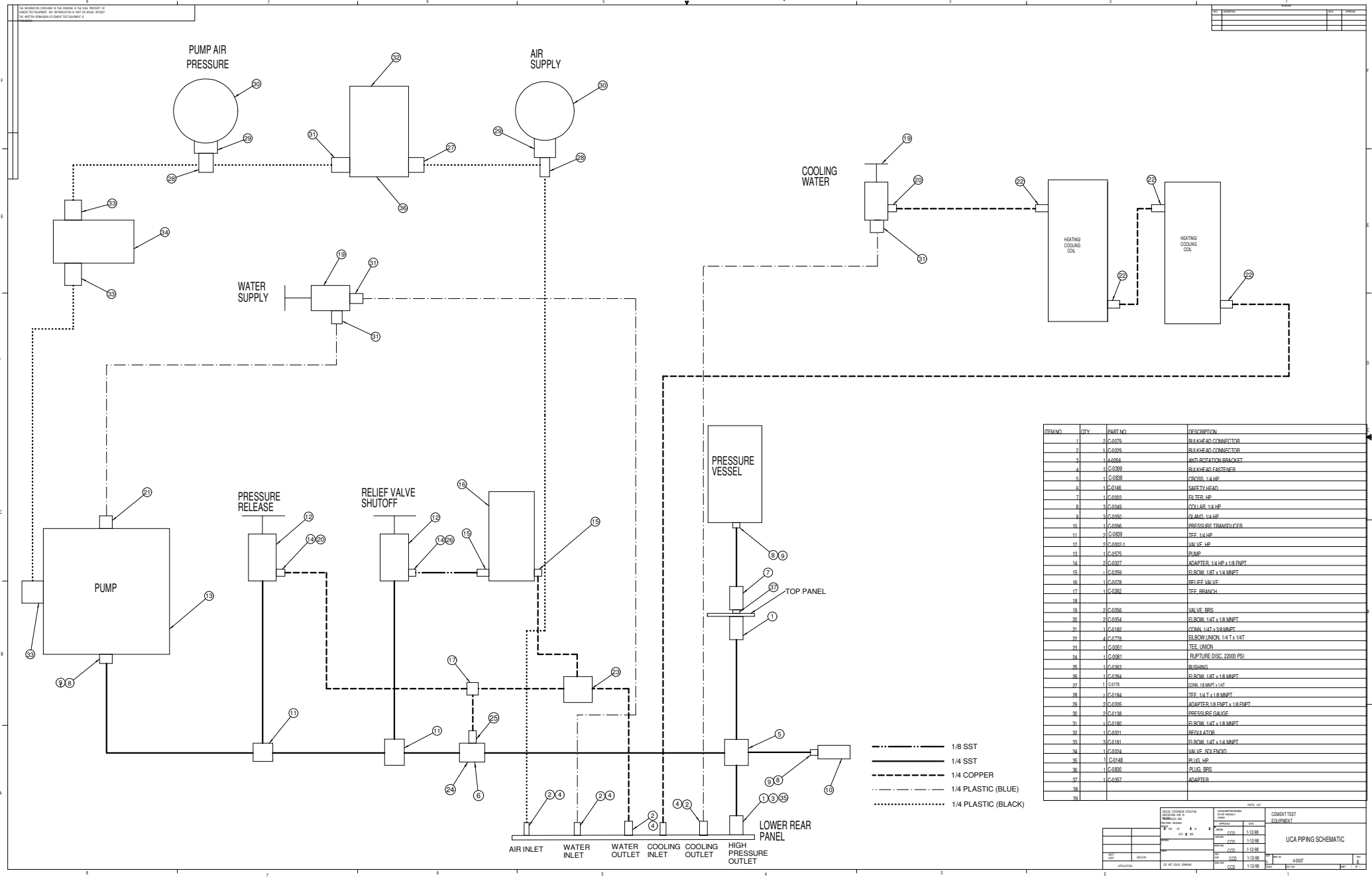

REFNO	QTY	PART NO	DESCRIPTION
1	2	C2073	BULKHEAD CONNECTOR
2	1	C2029	BULKHEAD CONNECTOR
3	1	A4056	ANTI-ROTATION BRACKET
4	1	C2399	BULKHEAD FASTENER
5	1	C2838	CROSS, 1/4 HP
6	1	C2195	SAFETY HEAD
7	1	C2053	ELBOW, 1/4 HP
8	3	C2040	COLLAR, 1/4 HP
9	3	C2050	FLAND, 1/4 HP
10	1	C2056	PRESSURE TRANSDUCER
11	2	C2839	TEE, 1/4 HP
12	2	C2000.1	VALVE, HP
13	1	C2575	PUMP
14	2	C2027	ADAPTER, 1/4 HP x 1/8 FNPT
15	1	C2626	ELBOW, 1/8 T x 1/4 MNPT
16	1	C2078	RELIEF VALVE
17	1	C2262	TEE, BRANCH
18	1	C2056	VALVE, BBS
19	2	C2054	ELBOW, 1/4 T x 1/8 MNPT
20	2	C2054	ELBOW, 1/4 T x 3/8 MNPT
21	1	C2182	DOWN, 1/4 T x 3/8 MNPT
22	4	C2772	ELBOW UNION, 1/4 T x 1/4 T
23	1	C2061	TEE, UNION
24	1	C2061	TRIPTURE DISC, 2000 PSI
25	1	C2053	ELBOW, 1/4 HP
26	1	C2394	ELBOW, 1/4 T x 1/8 MNPT
27	1	C2078	DOWN, 1/8 MNPT x 1/4 T
28	1	C2184	TEE, 1/4 T x 1/8 MNPT
29	2	C2026	ADAPTER, 1/8 FNPT x 1/8 FNPT
30	2	C2138	PRESSURE GAUGE
31	1	C2180	ELBOW, 1/4 T x 1/8 MNPT
32	1	C2091	REGULATOR
33	1	C2185	ELBOW, 1/4 T x 1/4 MNPT
34	1	C2074	VALVE, SOL ENDR
35	1	C2148	PLUG, HP
36	1	C2830	PLUG, BBS
37	1	C2457	ADAPTER
38			

DATE CHANGED		BY		REASON FOR CHANGE		APPROVED		DATE	

TEST		DATE		BY		APPROVED		DATE	

ITEM NO.		DESCRIPTION		QUANTITY		UNIT	

TEST		DATE		BY		APPROVED		DATE	

UCA PIPING SCHEMATIC

